

FOUR-KITCHEN

Ecology Unit





GENERAL FEATURES

- Ideally manufactured for the kitchens with chimney problems. It is environmentally friendly.
- It is manufactured with the capacity between 2.100-10.500 m³/h depending on the exhaust flow rate and kitchen size.
- It has a double-walled, Eurovent certified panel structure in thickness of 50mm. Inner wall is manufactured from stainless steel AISI304 quality.
- It is able to filter and clean odor and smoke by 99% in exhaust air by virtue of "Electrostatic Filter" and "UV-C Filter".
- Removes possibility of performance loss due to its specially designed automatic driven EC / DC motor plug fans due to filter pollution.
- Specially manufactured in two different types as "With UV lamp [FOUR-KITCHEN UV]" and "Without UV lamp [FOUR-KITCHEN]."
- Principally it is ideally used in kitchens, hotels, hospitals, industrial facilities, business centers and offices.

1- TECHNICAL STRUCTURE

FOUR-KITCHEN, which has been developed specially for the places with chimney problem, has been manufacturing in modular structure. Thanks to its modular structure, the parts are separable thus it can be positioned at different points where it is necessary.

It consists of 50mm thickness, double-walled and Eurovent certified panels. Inner wall is manufactured from stainless steel AISI304 quality so it can be easily cleaned.

FOUR KITCHEN device is controllable through an automated system and compatible with the other equipment manufactured by Doğu HVAC Systems.

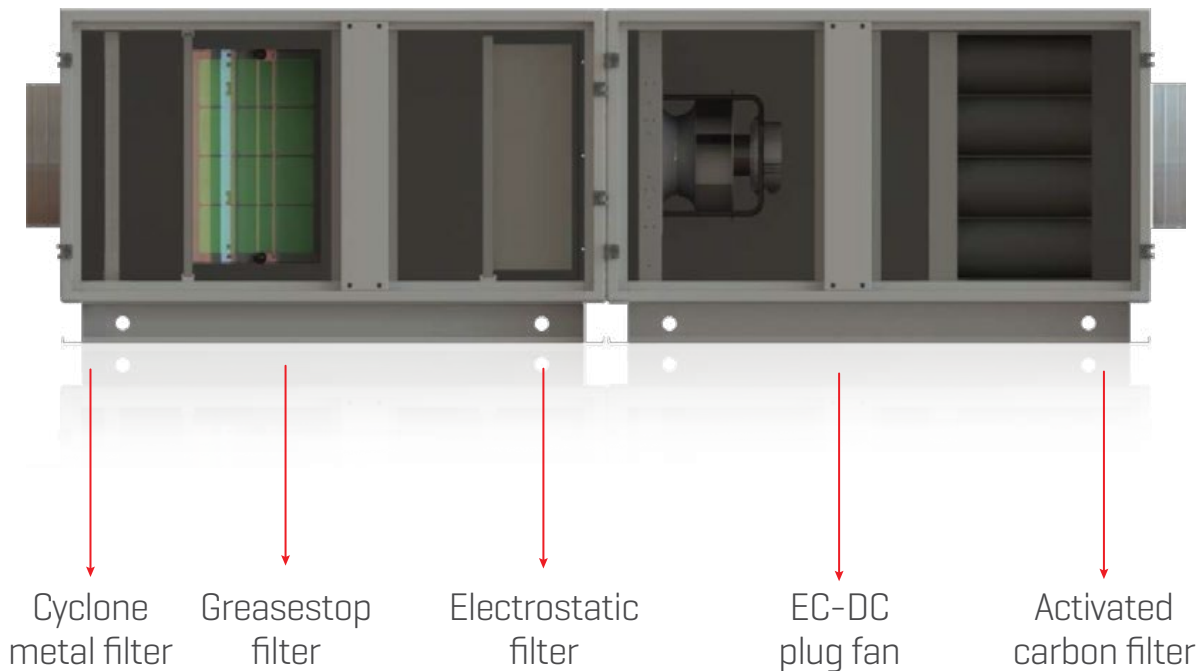

SPECIFICATIONS

- The inside walls of the device are manufactured from 304 stainless steel as standard. Taylor-made production is also available in line with the customer demand.
- Automatic control panel is supplied as standard with the device.
- Self-inverter, backward curved, EC-DC plug fan is used in device.
- Fan flow control unit is associated with the device as Standard.
- Upon request, remote-controlled fan flow control unit is supplied with the device.
- Double inclined condensation pan is available in the sections where the solid and liquid particles are caught.
- In case of request, it is able to be manufactured with mounted roofing sheet

Cyclone Filter

AG4 class cyclone flame repellent metal filter is used in device as the pre-filter. Thanks to this type of filter, the particles in size of 5 μm are able to be caught by 63% and particles of 10 μm by 95%. It has an anti-clogging design thus it can be used for longer times without the need of cleaning.

When it is filled, it can be easily removed from its place and washed thoroughly. It features a long time of use. It produces a constant and low pressure loss in the system. Cyclone filter is completely manufactured from stainless steel.



Cyclone filter

Greasestop Filter

The main objective of this filter is to catch oil and similar liquids in air current and also it serves to protect the electrostatic filter against various substances in liquid form.

Greasestop filters are able to catch the rough oil molecules by 99%.

“Greasestop filter” featuring high efficiency in oil catch is washable. In case of clogged, it can be washed by hand or in washing machine.

Following the washing process, it can be re-attached to its place after dried well then it continues to its function.

Thus it offers lower costs. To prevent any interruption in operation while the filter is getting dried, another filter set is supplied free of charge.



Greasestop Filter

Electrostatic Filter

Electrostatic filter, which is one of the most important parts of FOUR KITCHEN device is able to catch dust, particles, soot and other solid particles up to 0,3 μ [1 micron = 0,001mm] due to its highly efficient particle retention capability thus it offers high performance filtration solution.

On the other side, another important feature of the filter is that it is able to work with low pressure loss. It is shown in the following graph including the relation between the particle retention amount [gr] and the pressure loss [Pa].

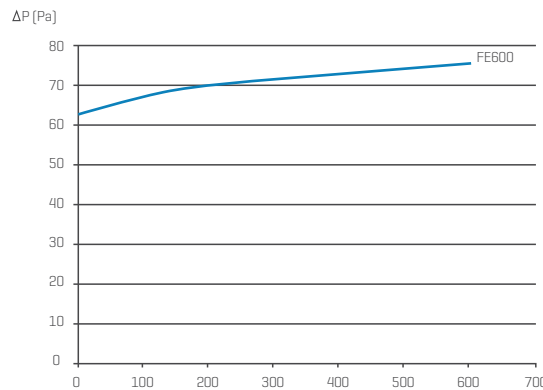

Clogging graph of full size electrostatic filter in gr for ISO12103-A2 dust class

In addition, electrostatic filter efficiency is also shown in the following graph in accordance with the results of the tests done in compliance with UNI 11254 standard.

Electrostatic filters having 10 to 15 year lifespan can be used for several times by washing in into a container filled with water thanks to its waterproof structure.

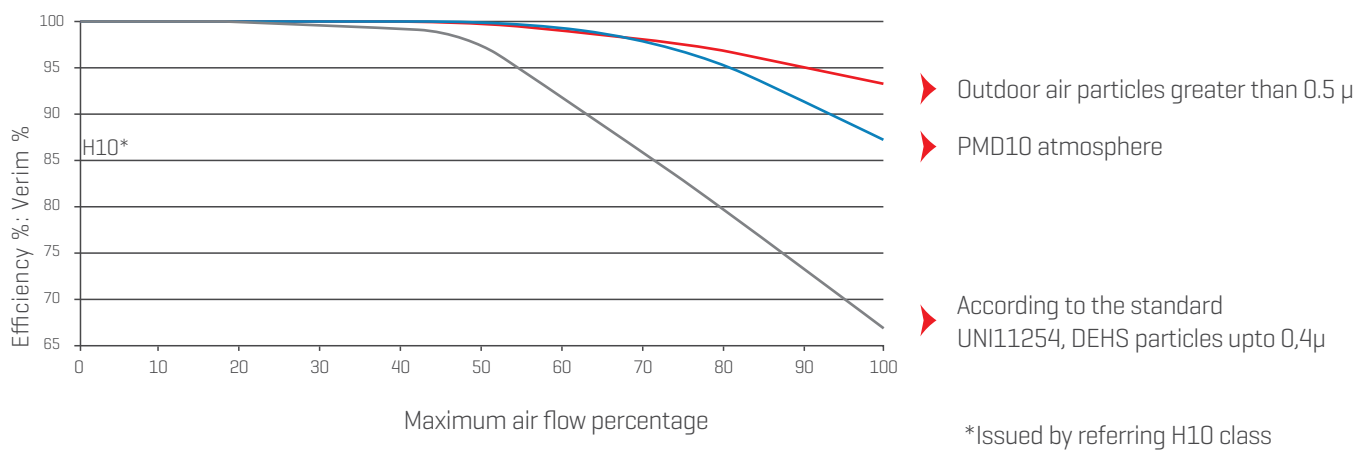

*Issued by referring H10 class

Electrostatic filters efficiency curve

The working principle of electrostatic filters is given as follows; all particles entering the filter first are electrically loaded with +/- then these particles are forced to pass through the plates electrically loaded with +/- . By magnetic force effect, the particles are directed to the plates thus filtered from the air current.

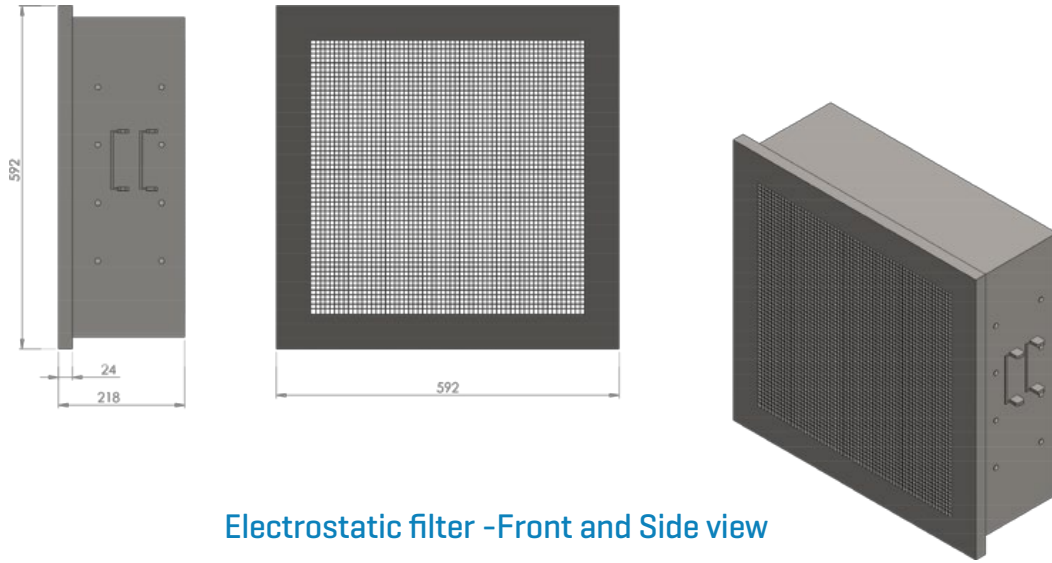

Electrostatic filter -Front and Side view

Filter efficiency	% 80-99
Performance	Full efficiency up to 600 gr particle accumulation
Input voltage	230 V - 50/60 Hz
Full Size [Width / Height] - Half-length filter	592/592 - 287/592 mm
Power consumption	9-16 Watt
Origin	Italy

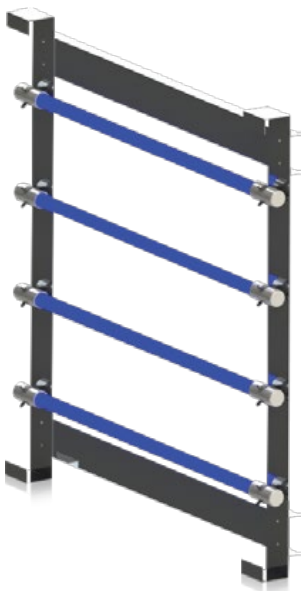

UV Lamp

UV Lamp

UV lamps that are offered optionally are used just after electrostatic filter.

Each type of oil molecules, odor and microorganisms are entirely destructed with short-wave electromagnetic heat-producing ultraviolet lamps (UV-C type). Maximum UV radiation can be achieved due to the lamps manufactured from the synthetic quartz glass. a

Some of the properties of UV lamps used are given as follows;

- Resistant up to 60 C.
- 4.8 [100 Watt] - 10 g / hour [220 watts] ozone production
- Thanks to its special glass coverage, lamps are prevented to have mercuric oxide layer. Thus, permanently high and fixed amount of ozone production can be achieved.
- Allows the longer life of activated carbon filter. The need of filter replacement remains at minimum level.
- No need for chemicals use, since there is no need for air duct cleaning and maintenance after use. Minimizes water and environmental pollution
- Removes any risk of fire inside the air duct
- It provides efficiency run of other ventilation units (fan, air ducts etc.) by protecting them against any dirt thus allows the air flow remains constant

On one hand, UV-C lamps are breaking all microorganisms, oil and other particles by emitting ultraviolet light and on the other hand they produce ozone gas and increase the efficiency of UV lamp. Ozone gas having the capability of high reaction reacts with all odor molecules and other organic/inorganic molecules thus provides these substances become harmless.

The inner walls of FOUR KITCHEN device is manufactured ozone protected and all other parts and cables are coated with protective layers against ozone.

Depending on usage, it has a life of over 10,000 hours.

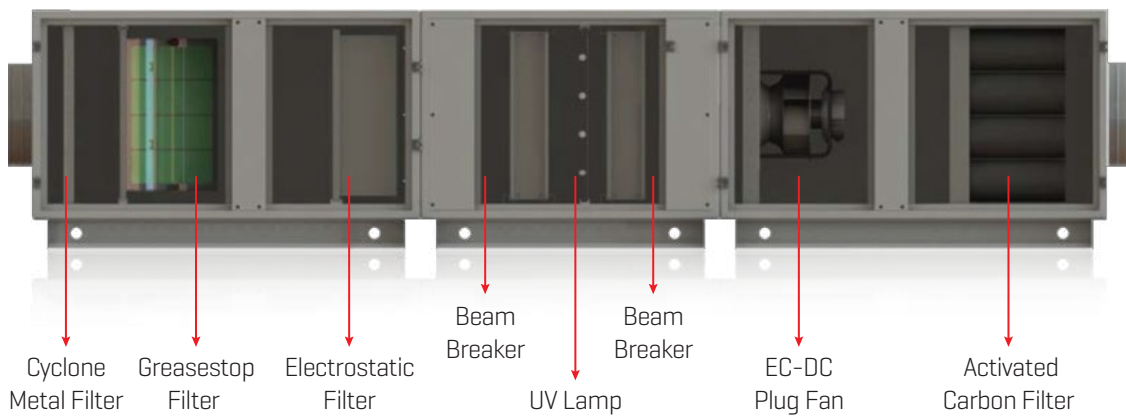

Activated Carbon Filter



Activated Carbon Filter

Cartridge type activated carbon filters are used on the device. Ideal solution is offered by adjusting the number of cartridges according to the flow and interior size.

Thanks to other filters used before this activated carbon filter, this filter has lower load and longer life of use significantly.

Thus the replacement cost of activated carbon filter that forms an important item of cost in operating expenses of the device can be lowered accordingly.

The activated carbon filters used in devices are able to catch food, burn fat and meat smell, soot, nicotine, the scent of flowers and other organic compounds. In addition, use of activated carbon filter prevents ozone gas produced by UV lamp to be released to air directly.



Plug Fan

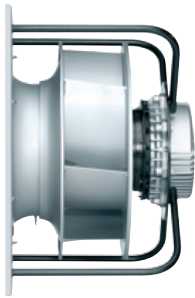

Fan

Considering low energy consumption, EC plug fans are preferred in FOUR KITCHEN devices.

These fans having high efficiency aerodynamic structure have rather low energy consumption and sound emission levels.

All fans are categorized in IP54 protection class. In view from rotor, these fans are appeared clockwise rotating backward curved aluminum fins fans. These fans that are automatically driven when the filters are clogged ensure to prevent efficiency decrease in filtration along with the time.

General characteristics of the fan are listed in the table below.

MODEL	Voltage [V]	Frequency [Hz]	Emitting noise [M]	Operating temperature °C
FOUR KITCHEN 21	380	50/60	53	-25/60
FOUR KITCHEN 42	380	50/60	56	-25/60
FOUR KITCHEN 63	380	50/60	49	-25/60
FOUR KITCHEN 84	380	50/60	48	-25/60
FOUR KITCHEN 105	380	50/60	56	-25/60

2- WORKING PRINCIPLE AND INSTALLATION

Air is first entering the device through cyclone filter and rough particles are caught. Then the oil filtration takes place with the oil holding filter. Air passing through these both filters enters electrostatic filter and here all particles up to $0,3 \mu$ are caught. UV-C lamps that are being offered optionally take part behind these filters.

The activated carbon filters are seen as the final section.

The odor in exhausted air can be caught through these filters significantly and the cleaned air is released.

FOUR KITCHEN device manufactured in modular structure is able to be used separately or entirely. The start- up is activated by the experienced technical staff of Doğu HVAC Systems then the system is delivered to the customer after the initial tests are completed.

3- DIMENSIONING – SELECTION

FOUR-KITCHEN

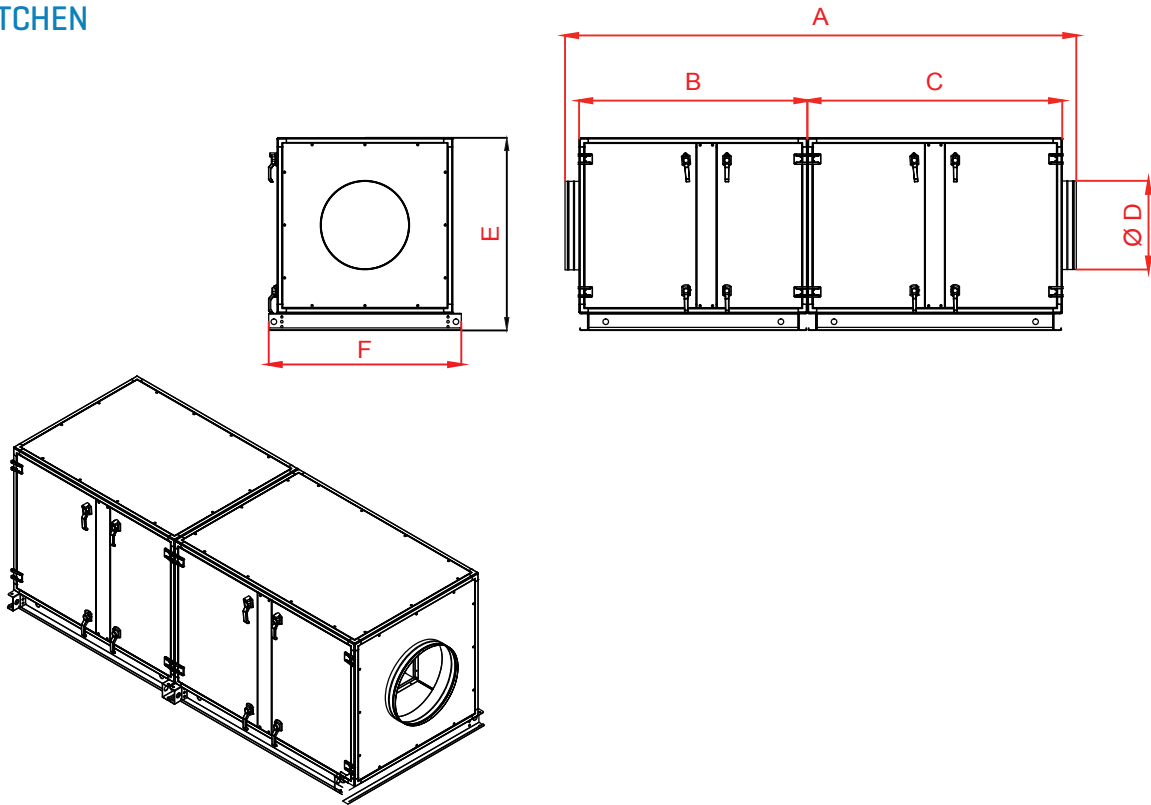

		Flow Rate	A	B	C	Inlet Outlet [ØD]	E	F	Weight	Power
MODELS		m ³ /h	mm	mm	mm	mm	mm	mm	Kg	kW
	FOUR-KITCHEN-021	2100	2860	1340	1340	Ø395	820	820	340	1,67
	FOUR-KITCHEN-042	4200	3015	1340	1495	Ø555	820	1440	630	3,04
	FOUR-KITCHEN-063	6300	3015	1340	1495	Ø705	1440	1130	690	3,53
	FOUR-KITCHEN-084	8400	2945	1340	1495	660x1280	1440	1440	810	5,45
	FOUR-KITCHEN-105	10500	2945	1340	1495	660x1590	1440	1750	910	5,6

FOUR-KITCHEN UV

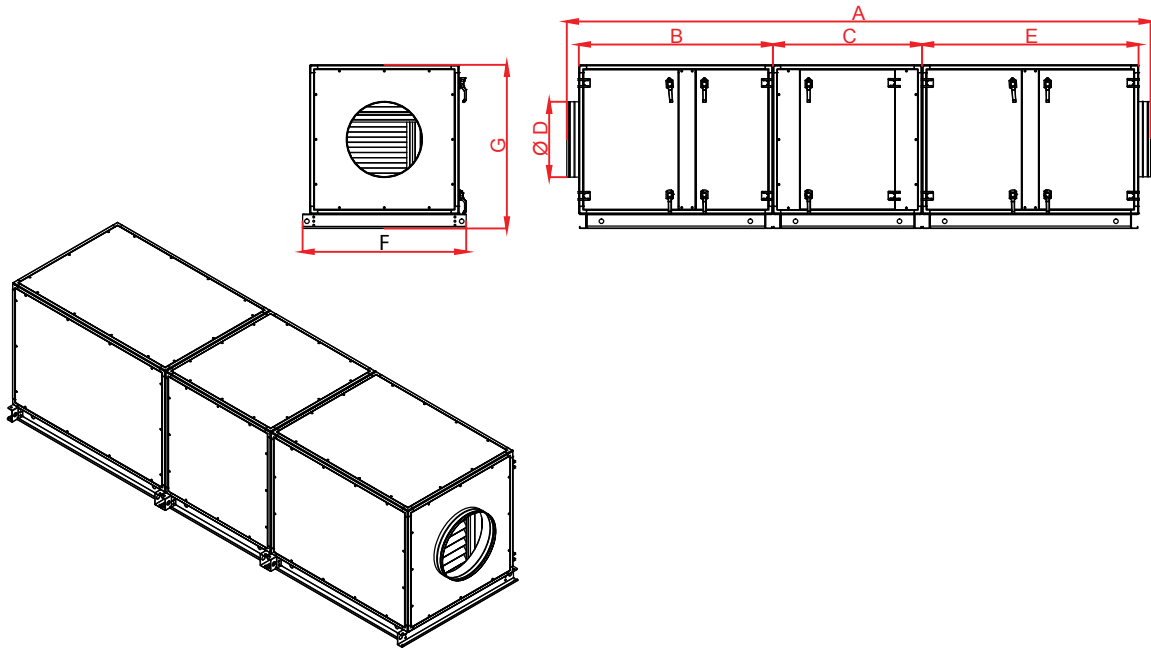

		Flow Rate	A	B	C	Inlet Outlet [ØD]	E	F	G	Weight	Power
MODELS		m ³ /h	mm	mm	mm	mm	mm	mm	mm	Kg	kW
	FOUR-KITCHEN-UV-021	2100	3890	1340	1030	Ø395	1340	820	820	470	2,07
	FOUR-KITCHEN-UV-042	4200	4045	1340	1030	Ø555	1495	1440	820	850	3,92
	FOUR-KITCHEN-UV-063	6300	4045	1340	1030	Ø705	1495	1130	1440	950	4,63
	FOUR-KITCHEN-UV-084	8400	3975	1340	1030	660x1280	1495	1440	1440	1080	6,77
FOUR-KITCHEN-UV-105	10500	3975	1340	1030	660x1590	1495	1750	1440	1200	7,36	

4- FILTER CAPACITIES FOUR-KITCHEN

		Particle Capture %					Odor Capture %	Grease Capture %	
		0,4 µ	≥ 99	99-95	95-90	90-80			< 80
		> 0,5 µ	99,6	99,5	98,4	97,3	93,2		
MODELS	FOUR-KITCHEN-021	Flow Rate [m³/h]	1300	1700	2100	2550	3360	90	95
	FOUR-KITCHEN-042		2600	3400	4200	5100	6720	90	95
	FOUR-KITCHEN-063		3900	5100	6300	7650	10080	90	95
	FOUR-KITCHEN-084		5200	6800	8400	10200	13440	90	95
	FOUR-KITCHEN-105		6500	8500	10500	12750	16800	90	95

- There are four distinct filter stages in the device.
- Solid and coarse particles are caught with flame repellent metal filter.
- GreaseStop filter stops rough oil particles by 99% and prevents passage of water vapor.
- Electrostatic filter catches particles with the efficiency by 99 %.
- Activated carbon filter eliminates odor by 90%.

FOUR-KITCHEN UV LAMP MODEL

		Particle Capture %					Odor Capture %	Grease Capture %	
		0,4 µ	≥ 99,5	99,5-96	96-91	91-85			< 85
		> 0,5 µ	99,8	99,6	99	97,8	94		
MODELLER	FOUR-KITCHEN-UV-021	Flow Rate [m³/h]	1300	1700	2100	2550	3360	99	99,9
	FOUR-KITCHEN-UV-042		2600	3400	4200	5100	6720	99	99,9
	FOUR-KITCHEN-UV-063		3900	5100	6300	7650	10080	99	99,9
	FOUR-KITCHEN-UV-084		5200	6800	8400	10200	13440	99	99,9
	FOUR-KITCHEN-UV-105		6500	8500	10500	12750	16800	99	99,9

- There are five distinct filter stages in the device.
- Solid and coarse particles are caught with flame repellent metal filter.
- GreaseStop filter stops rough oil particles by 99% and prevents passage of water vapor.
- Electrostatic filter catches particles with the efficiency by 99 %.
- Activated carbon filter eliminates odor by 90%.
- UV-C Lamps catch oil molecules in gas form by 99,9%.
- UV-C and activated carbon filters remove odor by 99%.
- Exhausted air through UV-C system is purified from microorganisms.

Factory

ITOB Organize Sanayi Bölgesi 10010 Sok.
No: 4 35473 Tekeli / Menderes / Izmir / TURKEY
Tel: +90 [232] 799 02 40 Faks: +90 [232] 799 92 04

Istanbul Area

Barbaros Mah. Çigdem Sok. No:1 Agaoglu My Office
Kat: 4/18 Atasehir/Istanbul
Tel: +90 [216] 250 55 45 Faks: +90 [216] 250 55 46

Ankara Area

Çetin Emeç Bulvarı 1065 Cad. [Eski 2.Cad] 1309 Sok.
No: B/4 Öveçler / Çankaya / ANKARA
Tel: +90 [312] 472 11 45 Faks: +90 [312] 472 11 46

www.doguhvac.com

